



**CBDC powered Smart PerFORrmance contractS for Efficiency, Sustainable,
Inclusive, Energy use**

D2.6 Reference architecture and components functionality

Report Identifier:	D2.6 Reference architecture and components functionality		
Work-package:	WP2	Task:	T2.3
Responsible Partner:	European Dynamics (ED)	Version Number:	1.00
Due Date	M25	Document Date	13/11/2024
Distribution Security:	PU	Deliverable Type:	R
Keywords:	Architecture, Digital components, Integration Updates		
Project website: https://fortesie.eu/			



Quality Control

	Organisation	Date
Editor	ED	01/11/2024
Peer review 1	GAR	11/11/2024
Peer review 2	IEECP	12/11/2024
Authorised by (Technical Coordinator)	ED	12/11/2024
Authorised by (Quality Manager)	ED	13/11/2024
Submitted by (Project Coordinator)	ED	13/11/2024

Legal Disclaimer

FORTESIE is an EU project funded by the Horizon Europe (HORIZON) research and innovation programme under grant agreement No. 101080029. The information and views set out in this deliverable are those of the author(s) and do not necessarily reflect the official opinion of the European Union. The information in this document is provided “as is”, and no guarantee or warranty is given that the information is fit for any specific purpose. Neither the European Union institutions and bodies nor any person acting on their behalf may be held responsible for the use which may be made of the information contained therein. The FORTESIE Consortium members shall have no liability for damages of any kind including without limitation direct, special, indirect, or consequential damages that may result from the use of these materials subject to any liability which is mandatory due to applicable law.

Copyright notice

© Copyright by the FORTESIE Consortium

This document contains information that is protected by copyright. All Rights Reserved. No part of this work covered by copyright hereon may be reproduced or used in any form or by any means without the permission of the copyright holders.

Table of Contents

List of Figures	5
List of Tables	7
Abbreviations	8
Executive Summary	9
1 Introduction	10
1.1 Project Introduction	10
1.2 Deliverable Purpose	10
2 Architecture and Components functionalities	12
2.1 Data integration for FORTESIE pilots	13
2.2 Integration of the Data Sovereignty component	15
2.2.1 Integration approach	16
2.2.1.1 Integration of data for Pilot 1 (Museum)	18
2.2.1.2 Integration of data for Pilot 2 (GAR)	19
2.2.1.3 Integration of data for Pilot 2 (VEO)	19
2.2.1.4 Integration of data for Pilot 2 (OKT)	20
2.2.1.5 Integration of data for Pilot 3 (Just)	21
2.2.1.6 Integration of data for Pilot 4 (COOP)	22
2.2.1.7 Integration of data for Pilot 5 (Cordia)	23
2.2.1.8 Integration of data for Pilot 6 (GKW)	23
2.2.1.9 Integration of data for Pilot 7 (Mesh)	24
2.3 Integration of the platform for building management	24
3 Conclusions	27

List of Figures

Figure 1 High level FORTESIE platform architecture.....	13
Figure 2 Data Sovereignty sub-components.....	16
Figure 3 Method 1: direct connection.....	17
Figure 4 Method 2: using esthesis AGENT.....	17
Figure 5 Method 3: using rest_to_eLP and esthesis Agent.....	17
Figure 6 Using esthesis EDGE.....	18
Figure 7 Data sovereignty module to the components.....	18
Figure 8 Pilot 1 high level data integration.....	19
Figure 9 Pilot 1 data integration.....	19
Figure 10 Pilot 2 (GAR) data integration.....	19
Figure 11 Pilot 2 (VEO) data integration.....	20
Figure 12 Pilot 2 (OKT) high level data integration.....	20
Figure 13 Pilot 2 (OKT) data integration.....	21
Figure 14 Pilot 3 high level data integration.....	21
Figure 15 Pilot 3 data integration.....	21
Figure 16 Pilot 4 high level data integration.....	22
Figure 17 Pilot 4 data integration.....	22
Figure 18 Pilot 5 high level data integration.....	23
Figure 19 Pilot 5 data integration.....	23
Figure 20 Pilot 6 data integration.....	23
Figure 21 Pilot 7 high level data integration.....	24
Figure 22 Pilot 7 data integration.....	24
Figure 23 MESH air monitoring system.....	25
Figure 24 Architecture for LoraWAN network case.....	25
Figure 25 Architecture for MESH proprietary network case.....	25

List of Tables

Table 1 FORTESIE Pilots.....	15
Table 2 FORTESIE Sensors.....	15
Table 3 Network comparison.....	26

Abbreviations

BIPV	Building Integrated Photovoltaics
BMS	Building Management System
CBDC	Central Bank Digital Currency
EPC	Energy Performance Contracting
ESIE	Efficient, Sustainable and Inclusive Energy
€G	Green-Euro
FAIR	Findable, Accessible, Interoperable, and Reusable
IEQ	Indoor Environmental Quality
IoT	Internet of Things
NGSI-LD	Next Generation Service Interface-Linked Data
RH	Relative Humidity
SSH	Social Sciences and Humanities

Executive Summary

This report provides a comprehensive overview of updates for the reference architecture of FORTESIE. It details the relevant updates of its components' functionalities. It is based on the previous version of the architecture, as outlined in the deliverable D2.3. FORTESIE system functionalities, the interfaces of the internal components of the system, as well as the foreseen interactions between components have been defined and updated, according to each pilot's needs. Since data needs to be communicated in a standardised format, the relevant data flows for the sub-components of the Data Sovereignty module have been updated. The report offers valuable insights into the implementation phase, highlighting the integration of data from multiple sources (sensing components, weather data and external systems). Therefore, multiple transformation methods are outlined, providing a clear picture of FORTESIE architecture updates, and ensuring standardisation and interoperability.

1 Introduction

1.1 Project Introduction

The overall vision of FORTESIE is to design, demonstrate, validate and replicate innovative renovation packages in the building industry with Smart Performance-Based guarantees and financing, aiming at Efficient, Sustainable and Inclusive Energy (ESIE) use to accelerate the Renovation Wave in Europe. The renovation packages will combine state-of-the-art construction materials and technologies components (prefabricated facades, BIPV, heat pumps, etc.), innovative digital technologies for measurement and verification, and attractive financing (e.g. contractual frameworks for smart performance guarantees, financing mechanisms, engagement techniques, green-euros, etc.), to raise the overall EPC value proposition. The renovation packages will be tailored to specific target groups' needs and optimised to improve the ESIE performance considering energy, CO₂ and comfort. Each package will be demonstrated and validated in real-life use cases and customised for replication in all other partner countries for immediate market take-up.

Methodologies from Social Sciences and Humanities (SSH) will be adopted for:

- a. the creation of collaborative business models that boost the Renovation Wave by considering all stakeholders' value and revenue streams,
- b. novel incentivisation and behavioural change models that aim to stimulate long-term engagement with focused interactions to adopt green behaviour
- c. the incorporation of a digital currency, €G for financing, rewarding and creating an inclusive / collective narrative in the fight against climate change
- d. the collection of feedback for recommendations to policy and business stakeholders,
- e. Mapping and understanding the complex interplay between the different stakeholders to deliver an engagement strategy across the value chain.

These demonstrations will potentially constitute the green-euro as a retail Central Bank Digital Currency (CBDC), hence revolutionising the financing of renovation approaches. An online marketplace will be offering first-level advice, directing consumers through the value chain of stakeholders and facilitating access to these “packaged” renovation services.

1.2 Deliverable Purpose

This deliverable offers a comprehensive update on the status of components' inter-connection identified in the deliverable D2.3 (Reference architecture and components). It provides insights into necessary architectural changes that occurred during the project. The current stage of implementation is aligned with the maturity of each digital component of FORTESIE architecture. Data needs to be communicated in a standardised format. Therefore, the relevant data flows for the sub-components of the Data Sovereignty module have been updated. These changes support the integration of data from multiple sources (sensing components, weather data and external systems), addressing a wide range of pilots cases' needs. For this reason, the required methods of data transformation have been incorporated, updating architecture and ensuring FAIR principles compliance, standardisation and interoperability. FORTESIE architecture update includes truly extensible and independent elements, making use of already-proven solutions, when possible, in order to enhance the interoperability with existing systems and maximise the final impact. Overall, this report serves as a valuable resource for understanding the relevant implementation for the software components, which constitute the FORTESIE platform. Where necessary, it also provides understanding on

the interfaces with the renovation components, covering requirements for privacy, legal/ ethical issues and data protection for all of the pilots.

2 Architecture and Components functionalities

The FORTESIE architecture components support a smooth operation process. Hardware and software components have been integrated, based on their maturity. The reference architecture is the basis for the FORTESIE platform, which unifies different interdisciplinary modules. By taking into consideration the user requirements and system requirements, FORTESIE converges into an overall platform that aims to provide a friendly and useful tool to the end users.

The FORTESIE project provides the measurement and monitoring of energy consumption with the dual aim to a. identify the performance improvements in the building/home in a standardised way, and document these in relation to the renovations implemented and connect these with EPC contracts offered by ESCOs, and b. to incentivise more energy efficient behaviour, personalised recommendations and the use of an alternative green-euro currency. The end-users will be able to use the FORTESIE application for both of these aims, and for this reason it receives data from the analytics, M&V and EPC module. Thus, the relevant measurements, analytics, recommendations and notifications are visualised. Also, energy consumption savings and green-euro earning can be monitored. Data Analytics, based on the Behavioural model and the Recommendation Engine, and the green-euro application balance can be available in the application through the relevant APIs. Multiple data sources (Data Sovereignty module and other data management platforms) are incorporated for FORTESIE, based on each pilot's requirements and needs.

In a high-level description, the FORTESIE architecture consists of several components and is depicted in the Figure 1. Data needs to be communicated in a standardised format. Therefore, two relevant data flows are implemented for each of the aim described above, enabling the communication of the sub-components of the Data Sovereignty module. For this reason the architecture has been slightly modified: Concerning the first flow, measurements from sensors and weather data are available directly to the Data Sovereignty component through the relevant data transformation and from there to analytics, M&V and EPC modules. The final result of the bonus/malus and monthly payment for the EPC contract and if available any green Euro reward is calculated. This flow utilises the blockchain where both M&V and EPC register the measured improvements and the smart contracts terms. For the second flow, the data from data sovereignty component is also transmitted to the analytics engine and then to the behaviour/recommendation engine to propose the hints and personalised tips for further improving the building performance.

The data is captured by the building in three different ways, that are influenced by the existing way of capturing data used in the building: a. data may be transmitted directly by sensors installed in the building, b. a gateway device gathers data from the building if sensors cannot transit directly to the data sovereignty platform (i.e. LORA network is not available at the specific location), c. data can be gathered by other systems such as Building Management Systems (BMS), monitoring systems and IoT (Internet of Things) backend systems. For these reasons, three alternative connectivity methods have been developed and integrated to facilitate future integration and avoid new developments. These changes support the integration of data from multiple sources (sensing components, weather data and external systems), serving a wide range of needs for the pilots. These methods of data transformation have been incorporated, updating FORTESIE architecture accordingly, ensuring FAIR principles compliance, standardisation and interoperability.

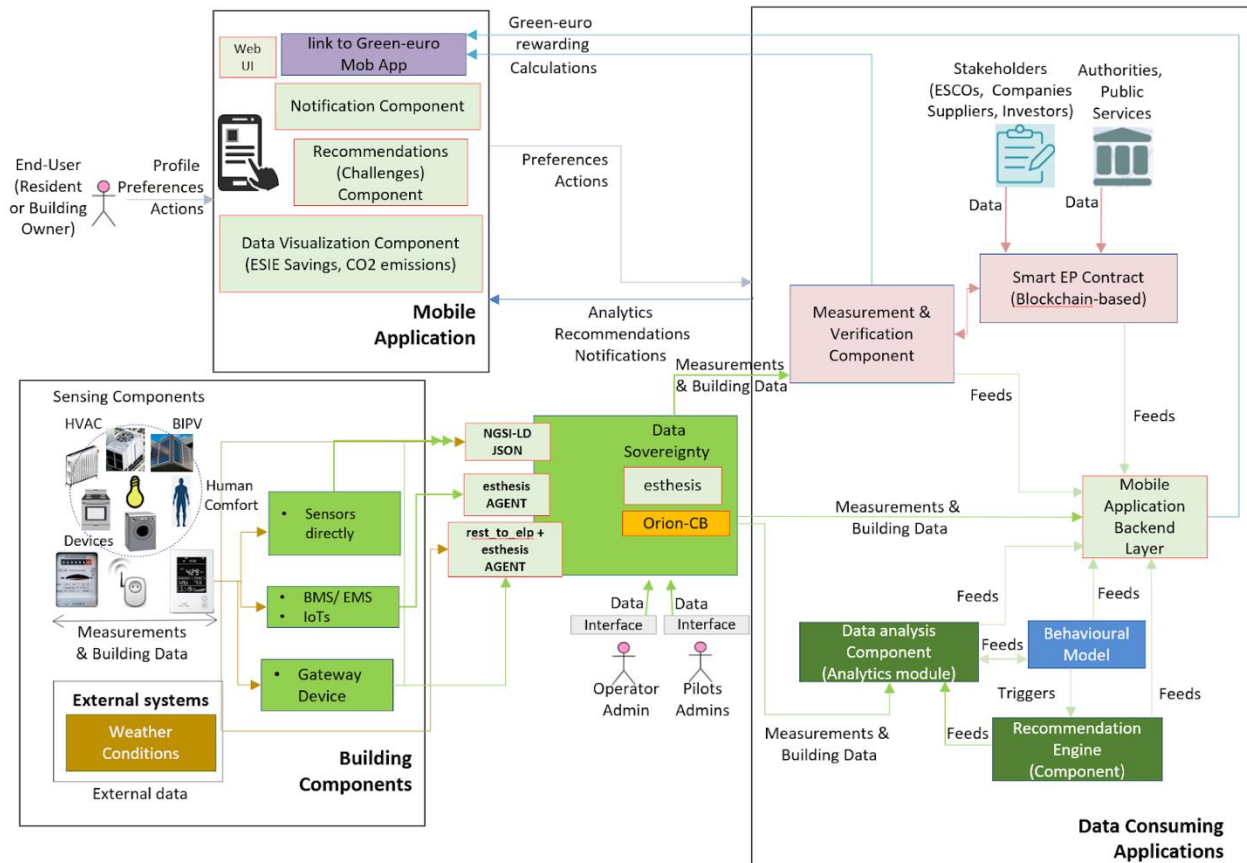

Figure 1 High level FORTESIE platform architecture

2.1 Data integration for FORTESIE pilots

The Data Sovereignty component of architecture includes data that needs to be communicated in a standardised format. This data originates from multiple sources, addressing a wide range of needs for the pilots. For this reason, different methods of data transformation have been incorporated. These implementations have changes per pilot and have been based on a common data model harmonisation, defined for the data integration across FORTESIE pilots.

The data integration process is based on the following and is split into two pillars:

- a. FORTESIE Data model
- b. FORTESIE naming convention

The FORTESIE data model contributes to the harmonisation of data across pilots and brings significant benefits to the FORTESIE project by ensuring consistency and interoperability among diverse data sources. A unified data model allows data from different sensors, devices and systems to be seamlessly integrated and understood in a common framework. This harmonisation facilitates efficient data exchange and analysis, reducing complexity and potential errors in data translation. It accelerates development and deployment

processes by providing a standard approach to data handling, which enhances collaboration among stakeholders. Ultimately, a consistent data model improves the reliability and scalability of the system, enabling more effective monitoring, control, and optimization of building environments across all pilot projects.

To ensure compliance with the NGSI-LD standard and FAIR principles throughout the project, the FORTESIE Data Model¹ was developed based on the Smart Data Models initiative. This data model provides a standardised framework for data modelling, ensuring that different systems and devices can communicate effectively. Such standardisation is vital for interoperability, enabling various components within the FORTESIE ecosystem to work seamlessly together regardless of their manufacturers or developers. The FORTESIE Data Model includes all relevant measurement quantities from any sensors anticipated to be installed across all FORTESIE pilot projects. All technical partners were involved in the creation process of the data model. The second iteration of the FORTESIE Data Model update has been completed.

Furthermore, a crucial aspect of developing the overall architecture of FORTESIE is the protection of pilot participants' data. Data anonymization is achieved at the point of data generation, ensuring privacy from the outset. Pilot representatives possess the information linking the real identities of homeowners to the Uniform Resource Names (URNs) representing all generated measurements and shared access to the various digital components of the FORTESIE architecture.

Each URN adheres to a specific template:

urn:ngsi-ld:fortesie:PILOT_NAME:BUILDING_ID:INSIDE_BUILDING_ID:SensorName-XXXX-Measurement

Where:

- **PILOT_NAME:** The name of the pilot, as specified in Table 1.
- **BUILDING_ID:** An alphanumeric identifier for the building, set by the pilot.
- **INSIDE_BUILDING_ID:** An optional alphanumeric identifier for the flat or room within the **building**, set by the pilot.
- **SensorName:** The name of the sensor used to gather the measurement, according to Table 2.
- **XXXX:** A sequential number assigned to the sensor within the pilot.
- **Measurement:** The name of the measurement (e.g., relativeHumidity, volatileOrganicCompoundsTotal) following the FORTESIE data model.

This structured URN format ensures consistent and anonymous identification of data sources across the FORTESIE ecosystem. It facilitates secure data sharing and interoperability while preserving the privacy of participants, aligning with the project's commitment to data protection and ethical standards.

¹ https://github.com/konstantinosGombakis/FORTESIE_data_model

Table 1 FORTESIE Pilots

PILOT_NAME	Pilot
demo_1	The Museum of the Society of Hellenism and Philhellenism
demo_2_gar	San Vicente neighbourhood in El Entrego [GAR]
demo_2_veo	FASA district residential buildings in Valladolid (VEO)
demo_2_okt	OKTAVE: Family houses in the Grand Est Region [FR]
demo_3	Just a Change - Independent house in a Rural location [PT]
demo_4	Single-family houses members of Coopérnico [PT]
demo_5	Building of the HQ of G.S.I.S.P.A. in Athens
demo_6	Sports and Recreation Center at Góra Kalwaria
demo_7	Riga 9th Secondary School [LV]

Table 2 FORTESIE Sensors

SensorName	Functionality
eem	electrical energy (production or consumption)
tem	thermal energy (production or consumption)
ieq	Indoor air quality
mt	Detects the opening of doors or windows for climate control purposes.
ws	weather station

The URN of the relative humidity (RH) of an Indoor Air Quality sensor (IEQ) located on the room 1 (room_adf) in the building, building_dwd part of the Demo 4 (Single-family houses members of Coopérnico [PT]):

urn:ngsi-ld:fortesie:demo_4:room_adf:building_dwd:ieq-001-relativeHumidity

2.2 Integration of the Data Sovereignty component

The FORTESIE Data Sovereignty component is a cloud-based, multi service platform which handles the data collection of the sensing components and the external systems. It is responsible for storing the data, managing the deployed building gateways and providing API access to all the other FORTESIE sub-systems (Consuming Applications).

Data can be communicated in a standardised format through relevant integration of Data Sovereignty with the FIWARE platform (FIWARE Orion Context broker). Therefore, the Data Sovereignty Layer consists of Esthesis and FIWARE sub-components. The Esthesis platform focuses on the centralised management of IoT devices and the processing of collected data. Within this platform, the user can add and configure devices (Esthesis agents), create and manage dataflows, and configure the security aspects of the connected devices and services.

In FORTESIE, the Data Sovereignty component gathers data from other FORTESIE components, through connection to the relevant data sources (sensing and actuating components). It provides data to other applications for processing and decision making. The Data Sovereignty will be run on a single kubernetes cluster. A common data model has been defined and updated to ensure FAIR principles compliance, standardisation and interoperability. Also, open and reusable sub-components have been used and three custom IoT agents have been developed to meet the specific needs of each pilot.

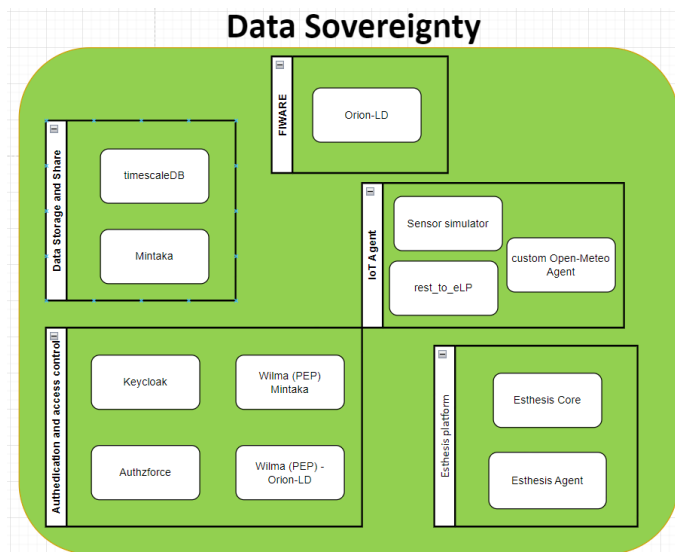

Figure 2 Data Sovereignty sub-components

2.2.1 Integration approach

For the needs of FORTESIE pilots, the sensors' data include measurements of Indoor/ Outdoor temperature, RH, as well as power and energy consumption/production.

Data Sovereignty module gathers input:

- from all sensing devices
- from the Analytics component
- local weather through the gateway device or an open-source service (Custom IoT Agent)

Currently, the Data sovereignty module supports 3 methods to receive measurements:

- Direct (Figure 3) the sensors provide their data to NGSI-LD compatible format, connect to the Orion-LD using the FORTESIE security methodology
- By esthesis AGENT (Figure 4) the sensors transform their data to eLP (esthesis Line Protocol) and send their data to a local esthesis AGENT. The AGENT sends via secure communication (mTLS) the measurements to the esthesis CORE, where they are transformed into NGSI-LD to be sent to Orion-LD
- By rest_to_eLP and esthesis AGENT (Figure 5) by customization of the IoT Agent rest_to_eLP to read the data from external REST API provided by the IoT sensors and transform the measurements to a compatible eLP format, to be sent to the esthesis AGENT.

All measurements are stored centrally in TimescaleDB. Through Mintaka software, digital components can access these measurements. To add or update any data, digital components (i.e. data analytics) must utilise Orion-LD, which is the only component with write access to TimescaleDB. Mintaka, in contrast, has read-only access to the database.

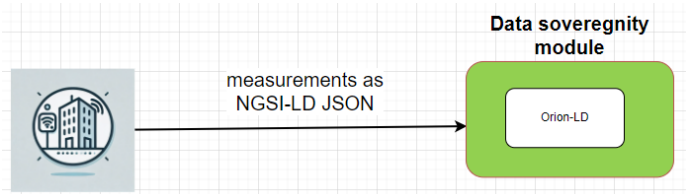

Figure 3 Method 1: direct connection

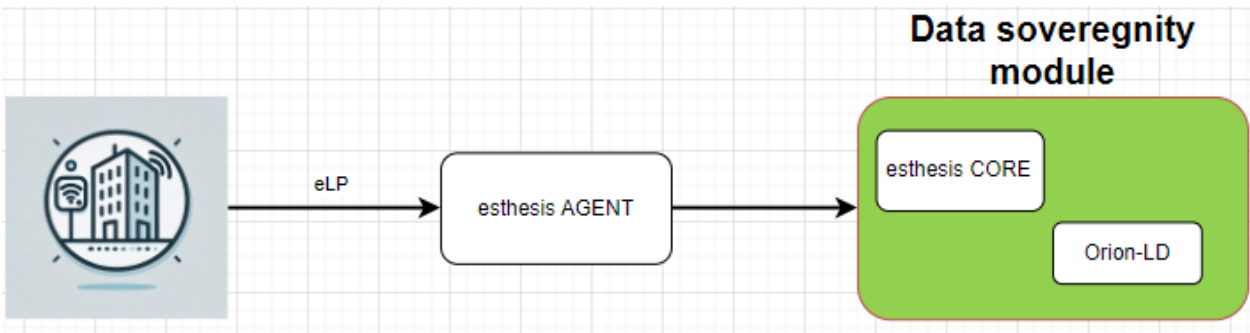

Figure 4 Method 2: using esthesis AGENT

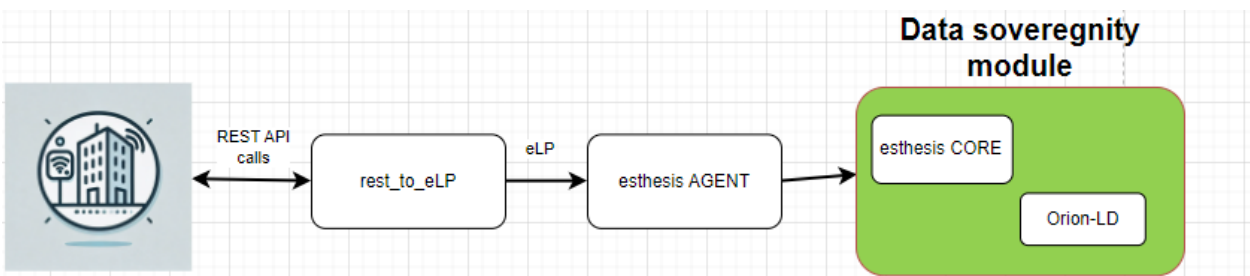

Figure 5 Method 3: using rest_to_eLP and esthesis Agent

The initial approach was that all pilots would push/send their measurements in a compatible NGS-LD JSON format to the Data Sovereignty module. If they did not have that option, we offer the Esthesis core, to be installed locally and provide the functionality of transforming the data from the esthesis Line protocol (eLP) to NGS-LD JSON. For some pilots without IT departments this process is not trivial, and Esthesis should facilitate this integration. Therefore a new component was introduced as part of the esthesis ecosystem, esthesis EDGE (Figure 6). The esthesis EDGE queries and receives data from external systems. To address the immediate need for receiving pilot measurements prior to the full implementation of the esthesis EDGE, an interim solution was developed: the IoT agent, restToEsthesis. The esthesis EDGE will simplify and remove the unwanted complexity of the current Method 3.

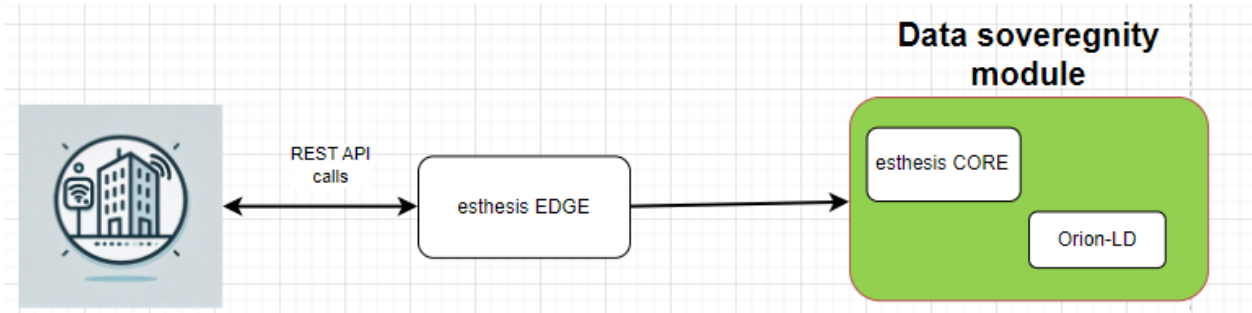

Figure 6 Using esthesis EDGE

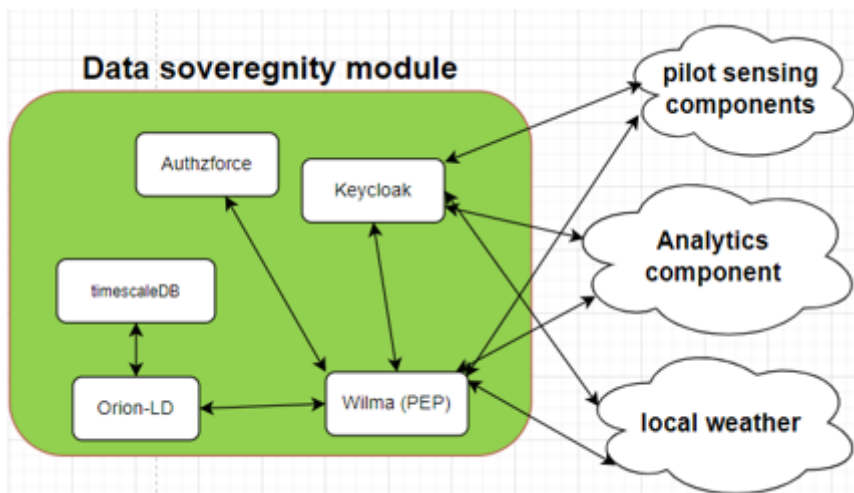

Figure 7 Data sovereignty module to the components

The Data Sovereignty module, through its relevant FIWARE sub-component, provides data as outputs to the following data consuming applications:

- FORTESIE mobile application, which provides visualisations to the end-users
- Recommendation Engine (responsible for behavioural triggers and challenges for the end users)
- Measurement & Verification (M&V) Component with the relevant data.

2.2.1.1 Integration of data for Pilot 1 (Museum)

The Demo 1 is a museum, located in the centre of Athens, Greece. The sensors' installation has been completed. The relevant measurements are gathered by Esthesis, which is a sub-component of Data Sovereignty, developed by European Dynamics. The sensors are communicating using Method 2.

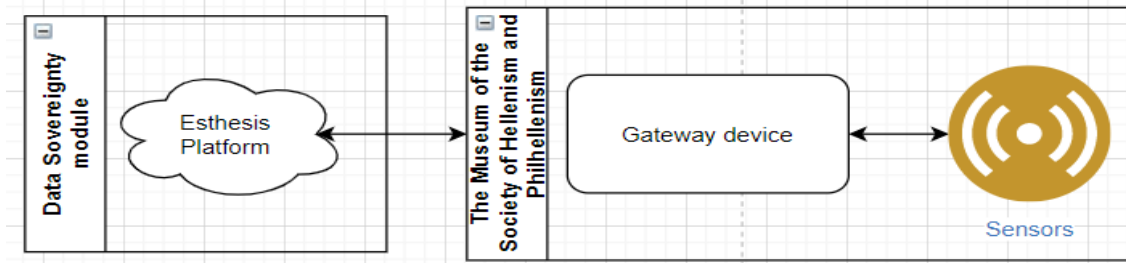

Figure 8 Pilot 1 high level data integration

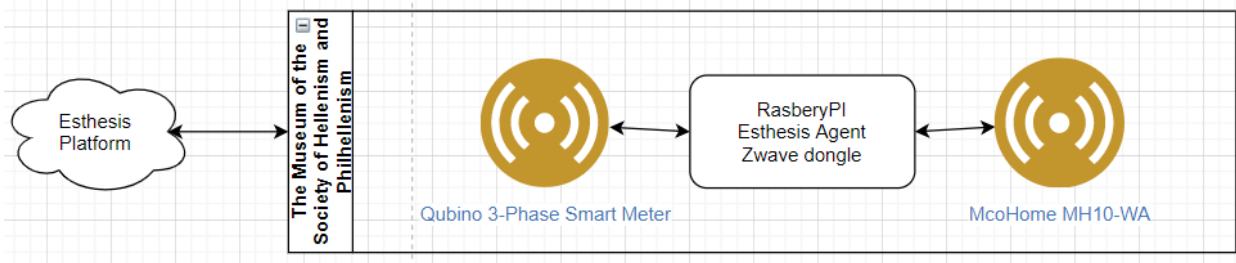

Figure 9 Pilot 1 data integration

2.2.1.2 Integration of data for Pilot 2 (GAR)

In the households of this pilot, sensors will transmit their data to a proprietary IoT system, called Centerlink. The Centerlink development team will process and transfer this data directly to the Data Sovereignty platform using Method 1.

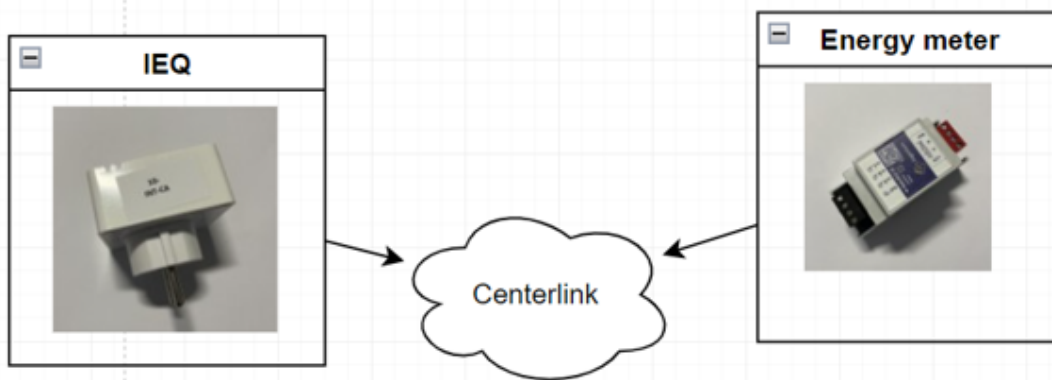

Figure 10 Pilot 2 (GAR) data integration

2.2.1.3 Integration of data for Pilot 2 (VEO)

In this pilot's households, Veolia's existing data collection system will supply FORTESIE with thermal consumption data per radiator, while MESH sensors will capture indoor environmental quality

measurements. All collected data will be stored within the Veolia central system and shared with the FORTESIE platform using Method 1.

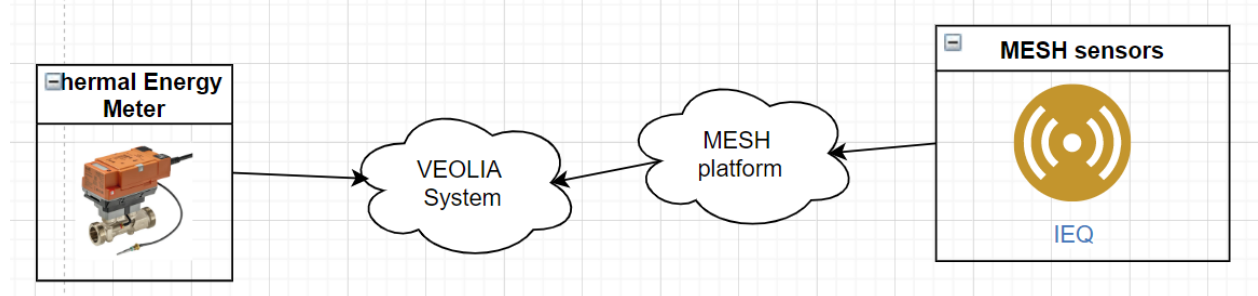

Figure 11 Pilot 2 (VEO) data integration

2.2.1.4 Integration of data for Pilot 2 (OKT)

Family houses in the Grand Est Region [FR]

For the family houses of this pilot, two data sources are integrated to support the Data Sovereignty module within the FORTESIE architecture. Specifically, IEQ data will be collected via the MESH platform and transmitted to the Data Sovereignty module using Method 3. Energy data will be supplied by Enedis, a utility company managing France’s electricity distribution network. The energy consumption data will be transferred from the Enedis platform to the Data Sovereignty module through its sub-component, Esthesis EDGE, currently in development. Enedis provides this data at no additional cost. Oktave has established a service account with Enedis, enabling access to the data upon homeowner consent.

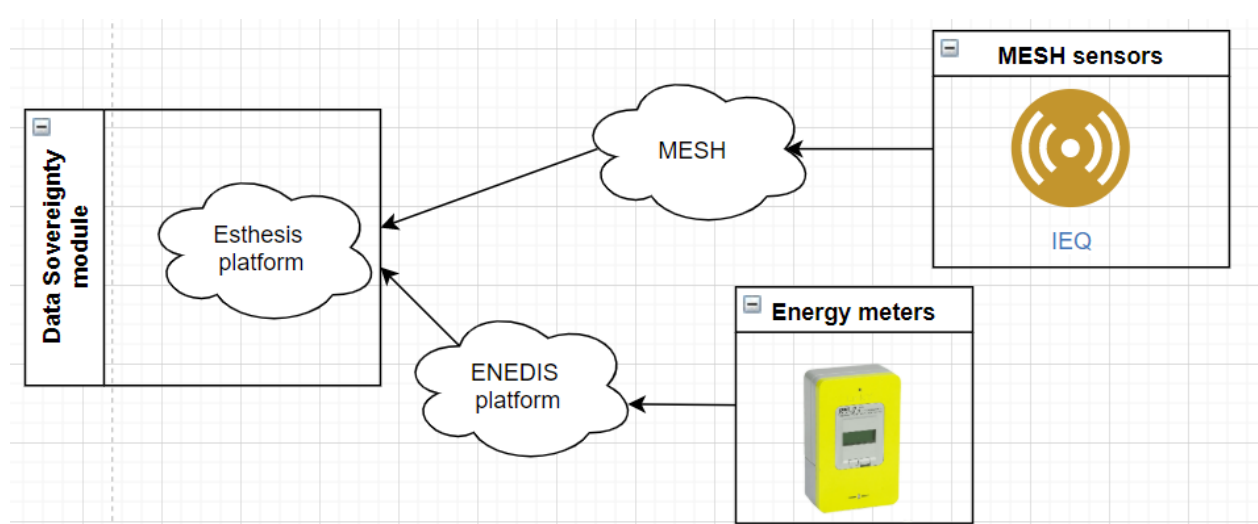

Figure 12 Pilot 2 (OKT) high level data integration

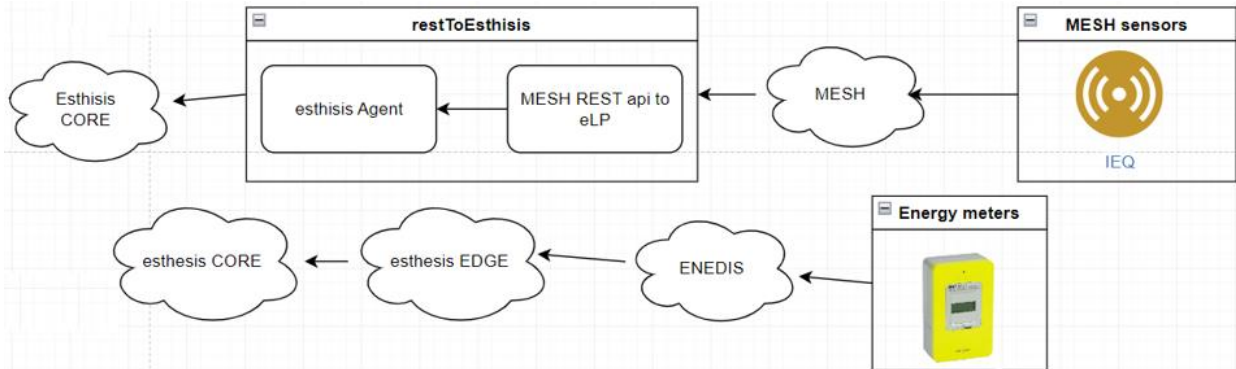

Figure 13 Pilot 2 (OKT) data integration

2.2.1.5 Integration of data for Pilot 3 (Just)

Just a Change - Independent houses in a Rural location [PT]

For the first of the ten houses, the installation of an Indoor environmental quality (IEQ) sensor (UNIPI model) has been completed. The relevant measurements, through MQTT, will be available to the FIWARE sub-component of the Data Sovereignty module.

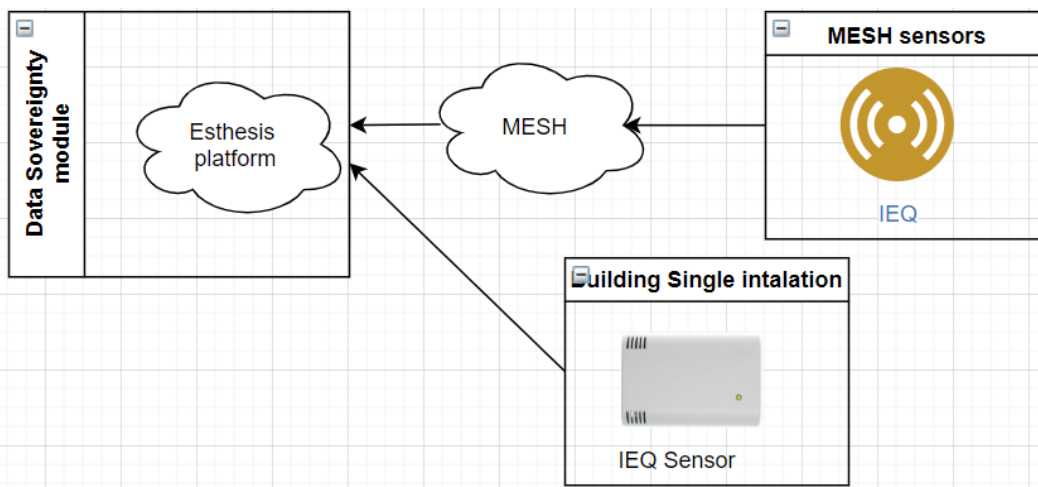

Figure 14 Pilot 3 high level data integration

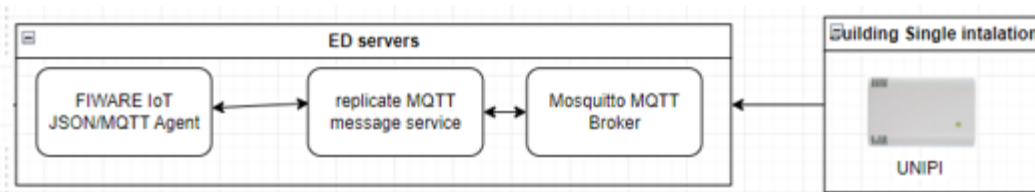

Figure 15 Pilot 3 data integration

For the rest of the houses, the data provided by the sensors installed is gathered by the MESH platform and transmitted to the Data Sovereignty module. Method 3 is utilised to share the data with the Data Sovereignty service.

2.2.1.6 Integration of data for Pilot 4 (COOP)

Single-family houses members of Coopérnico [PT]

For this demonstration, the sensor installation has been completed. The relevant data is collected by the MESH platform and transmitted to the Data Sovereignty module. Energy consumption and production data will be provided through the Coopernico API. Method 3 is used to share data with the Data Sovereignty service in both cases.

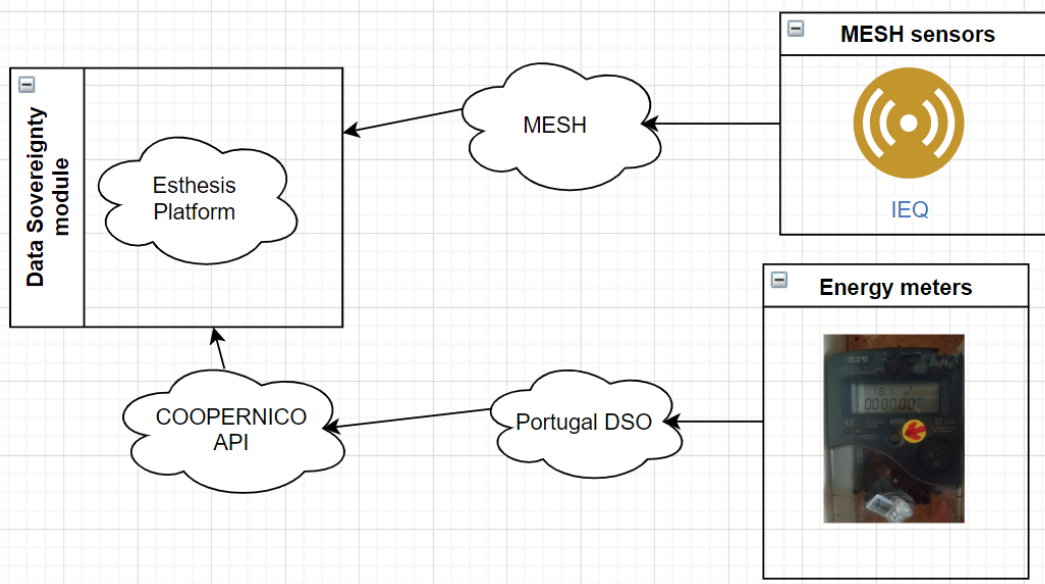

Figure 16 Pilot 4 high level data integration

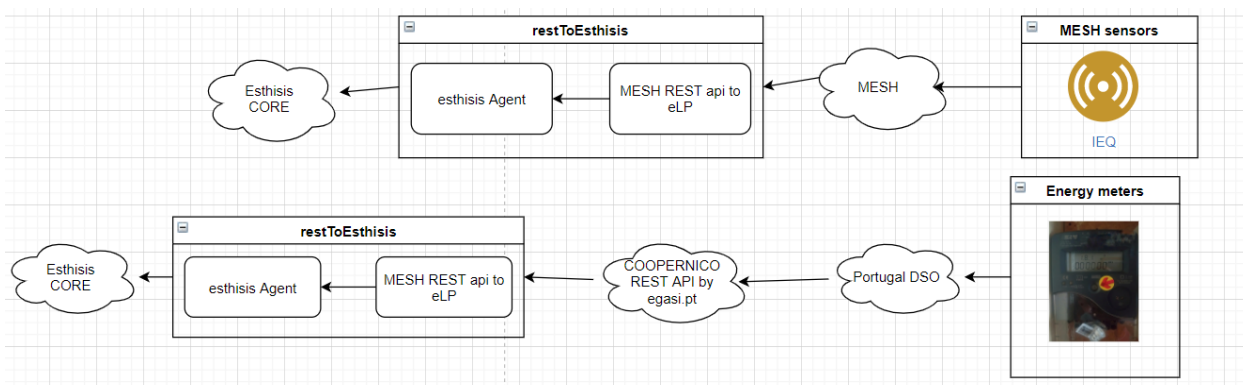

Figure 17 Pilot 4 data integration

2.2.1.7 Integration of data for Pilot 5 (Cordia)

Building of the HQ of G.S.I.S.P.A. in Athens [GR]

For the building of this demo, the sensors' installation has been completed. The relevant data is gathered by the Cordia Web BMS platform and provided to the Data Sovereignty module. The integration of the Data Sovereignty module with the Cordia Web BMS platform has been finalised. For the implementation of this connection, a relevant IoT agent has been developed. The second method has been implemented. A similar approach is under investigation also for Pilot 6.

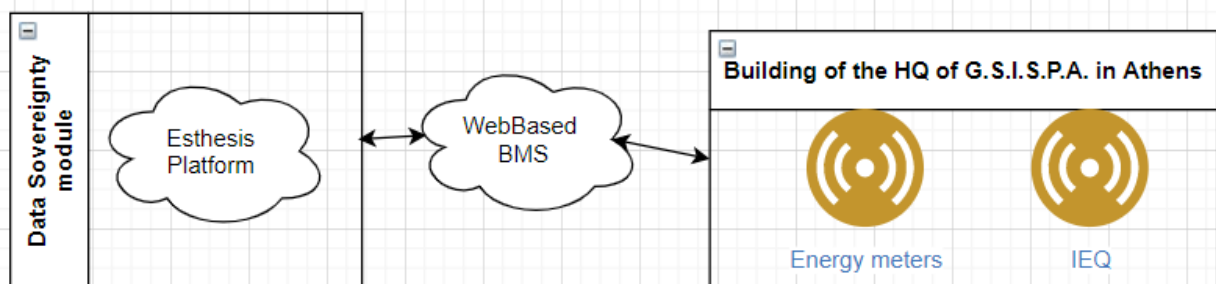

Figure 18 Pilot 5 high level data integration

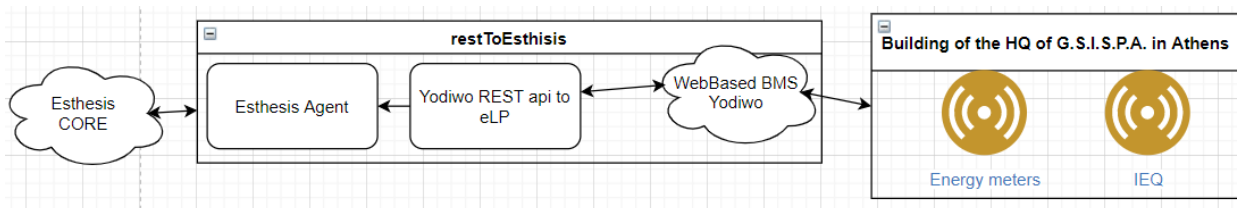

Figure 19 Pilot 5 data integration

2.2.1.8 Integration of data for Pilot 6 (GKW)

This demo refers to a pool. The relevant sensors under installation will provide measurement to a Building Management System (BMS). An approach similar to the Pilot 5 data integration is under investigation.

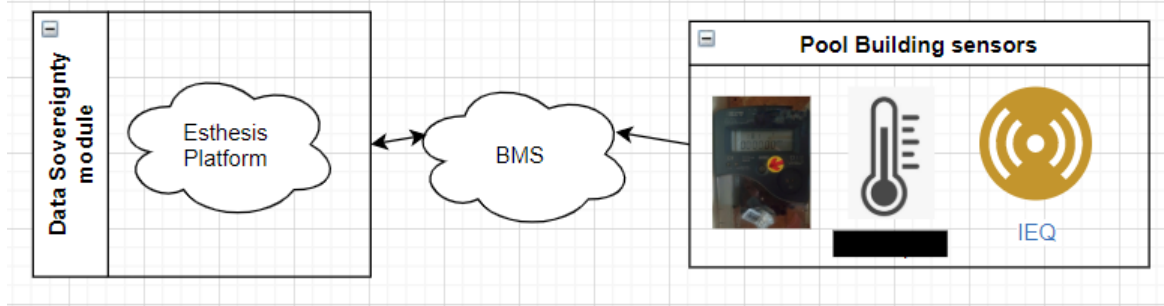

Figure 20 Pilot 6 data integration

2.2.1.9 Integration of data for Pilot 7 (Mesh)

Riga 9th Secondary School [LV]

For this demo the sensors installed provide the relevant measurements to the MESH platform. The integration of this platform with the Data Sovereignty module will make the needed data available to the FORTESIE platform. Method 3 is utilised to share the data with the Data Sovereignty service.

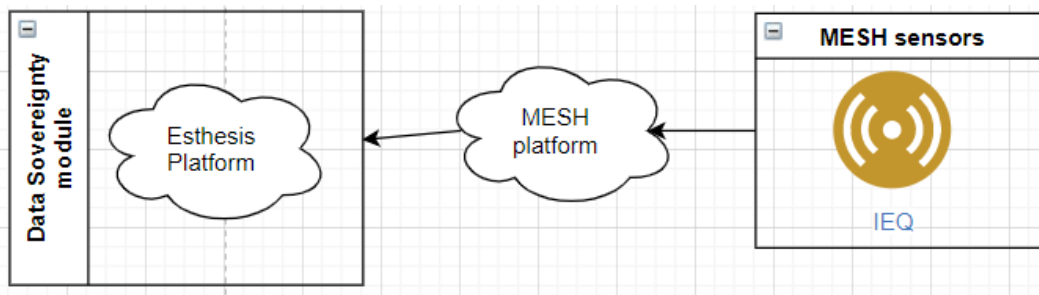

Figure 21 Pilot 7 high level data integration

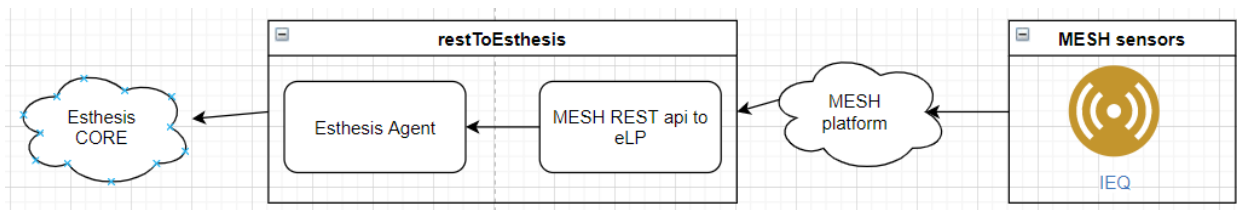

Figure 22 Pilot 7 data integration

2.3 Integration of the platform for building management

For the needs of all pilots with households, MESH provided a competitive solution, keeping the costs low. Therefore, an additional module was developed and integrated for Lora protocol (LoraWAN/Helium). The option of using Lora network was chosen because of existing private loraWAN network operation in the pilot case countries and energy efficiency advantages. The developed system by MESH consists of an air parameter monitoring screen, as shown in Figure 23. It incorporates high-accuracy air parameter monitoring sensors and adaptive networking functionality. It is made of high-quality materials (glass and plastic) making it a thoughtful addition for the interior of the room.



Figure 23 MESH air monitoring system

Necessary parameters are shown through the relevant screen, thus informing a user about the current indoor air parameters. Three sensor buttons (blue, red and green arrows) enable the interaction with the graphic user interface for additional features that could be developed in future software releases.

This air monitoring system is a fully autonomous battery-powered device, but in order to provide air parameter data synchronisation with the Data Sovereignty component of FORTESIE platform (esthesis), it uses internal multi-network functionality. The device uses either the LoraWAN network provided by Helium IoT (if the network is available) or the proprietary MESH network provided by the proprietary MESH Gateway, as shown in the following figures. Both comply with the constraints of energy efficient battery powered device.

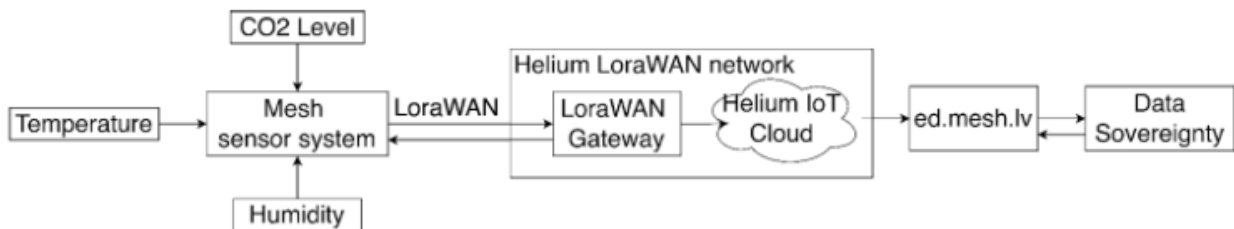

Figure 24 Architecture for LoraWAN network case

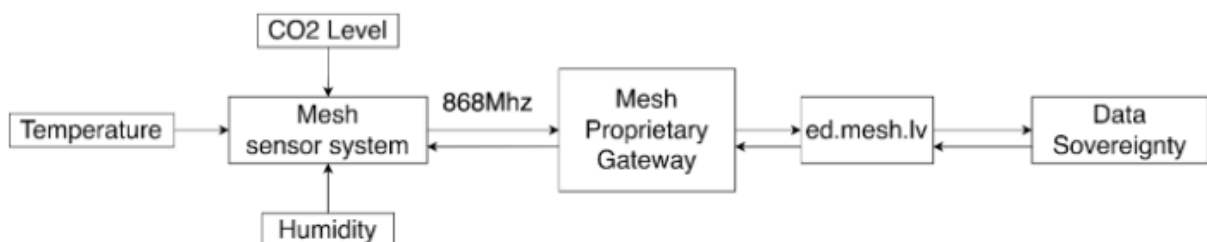

Figure 25 Architecture for MESH proprietary network case

Both networks have their own advantages and disadvantages. The following table summarises them as a comparison of these networks.

Table 3 Network comparison

	LoraWAN	MESH
Availability	Need to comply with available gateways	Can be installed by technician
Range of transmission	Long range	Reduced range
Speed	Very low	Average
Energy efficiency	Less energy efficient	More energy efficient

3 Conclusions

Throughout this report, the overall architectural framework of the project is described through its individual interdisciplinary sub-systems, which contribute to the development and implementation activities. The foreseen interactions between components have been defined and updated, taking into account each pilot's needs.

This deliverable depicts the final version of the FORTESIE architecture, highlighting the needed updates for the relevant components, developed by the partners to ensure the successful realization of the goals of architecture. These updates ensure standardisation and interoperability. This report acts as a reference for the FORTESIE platform that will be completed and will be documented in the deliverable D3.3 (FORTESIE services-based integrated platform for demonstration).